

Tot Weighers in Your Choice of Digital or Mechanical

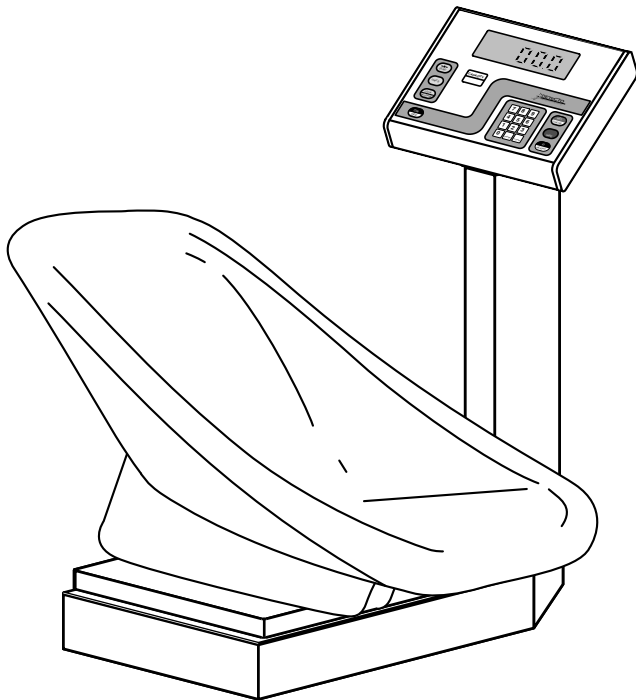

Model 8432-CH Digital Tot Weigher

- High contrast, digital display
- Soft, foam padded, inclined chair seat slips on and off
- Nonskid pads
- Heavy-duty, rust-resistant understructure
- Heavy steel base and precision lever system
- Digital head can rotate 90½ to either side
- Auto zero, auto shutoff, sleep, filtering, lock/release

Specifications

Capacity: 44 lb x .05 lb/20 kg x .02 kg (20g)
Display: .7" high-contrast LCD
Power: 6 "C" size Alkaline batteries (not included)
Color: White with gray pad
Options: 110 VAC in lieu of battery operation

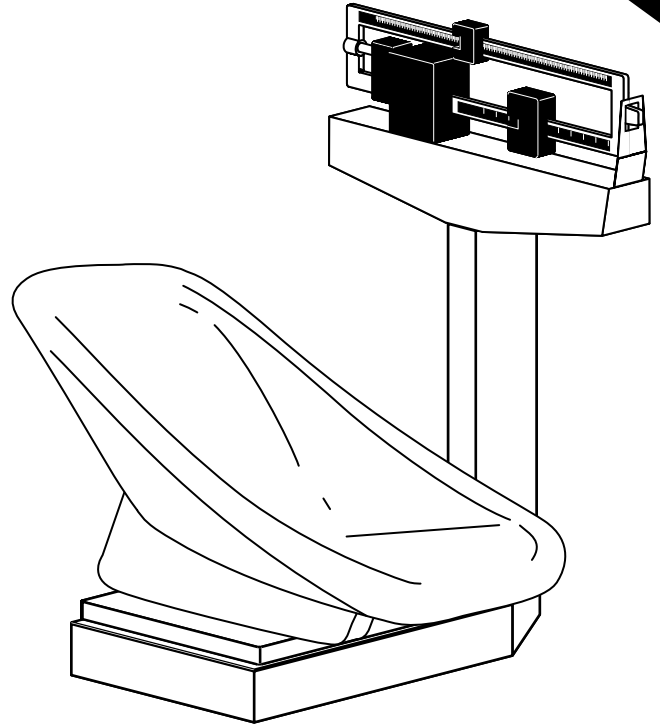

Model 459-CH Mechanical Tot Weigher

- Die-cast, dual-reading beam
- Soft, foam padded, inclined chair seat slips on and off
- Nonskid pads
- Heavy-duty, rust-resistant understructure
- Heavy steel base and precision lever system

Specifications

Capacity: 40 lb x .5 oz/17.5 kg x 10g
Display: Dual reading beam
Color: White with gray pad



Cardinal Scale reserves the right to improve, modify, or enhance features and specifications without prior notice.

